

SPECIFICATION OF THE DIGITAL AUDIO INTERFACE (The AES/EBU interface)

CONTENTS

1. Scope	2
2. Interface format	2
2.1. Terminology	2
2.2. Structure of format	3
2.3. Channel coding	5
2.4. Preambles	5
2.5. Validity bit	6
3. User data format	6
4. Channel status format	6
5. Interface format implementation	12
5.1. General	12
5.2. Transmitter	12
5.3. Receivers	13
6. Electrical requirements	13
6.1. General characteristic	13
6.2. Line driver characteristics	14
6.3. Line receiver characteristics	15
6.4. Connectors	16
Appendix 1 Generation of the CRCC (Byte 23) for channel status	17
Appendix 2 AES/EBU signals on Structured Wiring	19
Bibliography	20

Specification of the digital audio interface (The AES/EBU interface)

1. Scope

This document specifies a recommended interface for the serial digital transmission of two channels of periodically sampled and linearly represented digital audio data in a broadcasting complex, up to a distance of a few hundred metres,

Although this transmission specification is independent of sampling frequency it is intended that the interface be primarily used at 48 kHz, as this is the recommended sampling frequency for use in broadcasting studios (CCIR Recommendation 646).

The document does not cover connection to any common carrier equipment nor does it specifically address any of the questions relating to the synchronising of large systems, although by its nature the format permits easy synchronisation of receiving devices to the transmitting device.

Specific synchronisation issues are covered in document AES 11-1991.

Note 1: In this interface specification for broadcasting studio use, mention is also made of an interface for consumer use. The two interfaces are not identical.

Note 2: An engineering guideline document to accompany this interface specification is in course of preparation by the EBU.

2. Interface format

2.1. Terminology

For the purpose of this specification the following definitions of terms apply.

2.1.1. Sampling Frequency

The sampling frequency is the frequency of the samples representing an audio signal. When more than one audio signal is transmitted through the same interface, the sampling frequencies shall be identical.

2.1.2. Audio sample word

The audio sample word represents the amplitude of a digital audio sample. Representation is linear in 2's complement binary form. Positive numbers correspond to positive analogue voltages at the input of the analogue to digital converter (ADC). The number of bits per word can be specified from 16 to 24 in two coding ranges (less than or equal to 20 bits and less than or equal to 24 bits).

2.1.3. Auxiliary sample bits

The four least significant bits (LSB) can be assigned as auxiliary sample bits and used for auxiliary information when the number of audio sample bits is less than or equal to 20.

2.1.4. Validity bit

This bit indicates whether the audio sample bits in the sub-frame (time slots 4-27 or 8-27 depending on the audio word length as described in *Section 2.2.1.*) are suitable for conversion to an analogue audio signal.

2.1.5. Channel status

The channel status carries, in a fixed format derived from the block (see *Section 2.1.11.*), information associated with each audio channel, which is decodable by any interface user.

2.1.6. User data

The user data channel is provided to carry any other information.

2.1.7. Parity bit

The parity bit is provided to permit the detection of an odd number of errors resulting from malfunctions in the interface.

2.1.8. Preambles

Preambles are specific patterns used for synchronisation. There are three different preambles (see *Section 2.4.*).

2.1.9. Sub-frame

The sub-frame is a fixed structure used to carry the information described in *Sections 2.1.1. to 2.1.8.* (See *Sections 2.2.1. and 2.2.2.*).

2.1.10. Frame

The frame is a sequence of two successive and associated sub-frames.

2.1.11. Block

The block is a group of 192 consecutive frames. The start of a block is designated by a special sub-frame preamble (see *Section 2.4.*).

2.1.12. Channel coding

The channel coding describes the method by which the binary digits are represented for transmission through the interface.

2.1.13. Unit interval UI

Shortest nominal time interval in the coding scheme

2.1.14. Interface jitter

Deviation in timing of interface data transitions (zero crossings) when measured with respect to an ideal clock

2.1.15. Intrinsic jitter

Output interface jitter of a device that is either free running or is synchronized to a jitter-free reference

2.1.16. Jitter gain

Rate of transmission of frames

2.2. Structure of format

2.2.1. Sub-frame format

Each sub-frame is divided into 32 time slots, numbered from 0 to 31 (see *fig 1*)

Time slots 0 to 3 (preamble) carry one of the three permitted preambles (see *Fig. 2*) (see *Sections 2.2.2. and 2.4.*; see also *Fig. 2*).

Time slots 4 to 27 (audio samples word) carry the audio sample word in linear 2's complement representation. The most significant bit (MSB) is carried by time slot 27.

When a 24-bit coding range is used, the LSB is in time slot 4 (see *Fig. 1a*).

When a 20-bit coding range is sufficient, time slots 8-27 carry the audio sample word with the LSB in time slot 8. Time slots 4 to 7 may be used for other applications. Under these circumstances, the bits in the time slots 4 to 7 are designated auxiliary sample bits. (See Fig. 1b)

If the source provides fewer bits than the interface allows (either 24 or 20) the unused LSB shall be set to logic "0".

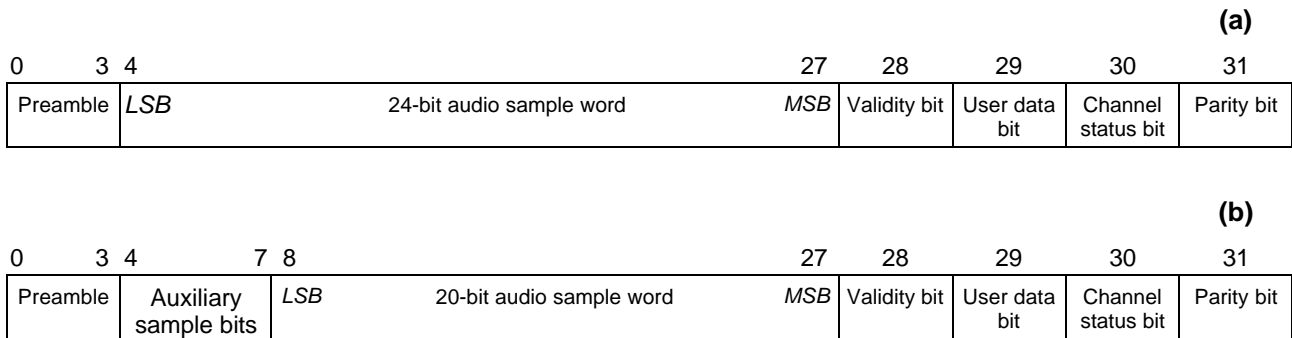

Fig. 1 – Sub-frame format for audio sample words of 24 bits (top) and 20 bits (bottom).

Time slot 28 (validity bit) carries the validity bit associated with the audio sample word (see Section 2.5).

Time slot 29 (user data bit) carries one bit of the user data channel associated with the audio channel transmitted in the same sub-frame (see Section 3).

Time slot 30 (channel status bit) carries one bit of the channel status information associated with the audio channel transmitted in the same sub-frame (see Section 4).

Time slot 31 (parity bit) carries a parity bit such that time slots 4 to 31 inclusive will carry an even number of ones and an even number of zeros (even parity).

Note: The preambles have even parity as an explicit property.

2.2.2. Frame format

A frame is uniquely composed of two sub-frames (see Fig. 2). The rate of transmission of frames corresponds exactly to the source sampling frequency.

The first sub-frame normally starts with preamble "X", however the preamble changes to preamble "Z" once every 192 frames. This defines the block structure used to organise the channel status information. The second sub-frame always starts with preamble "Y".

The modes of transmission are signalled by setting bits 0 to 3 of Byte 1 of channel status.

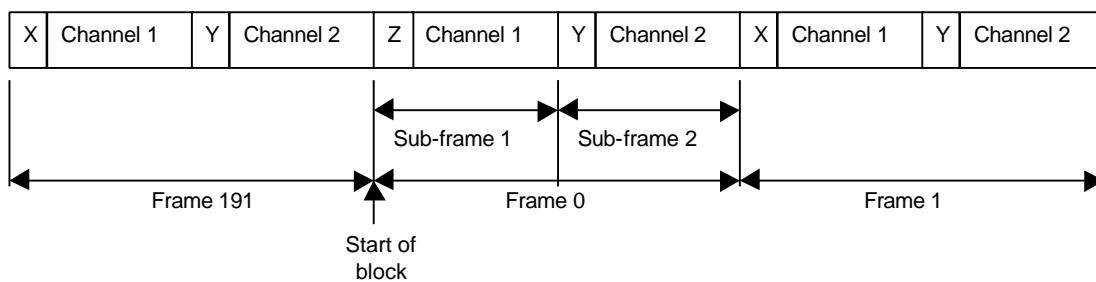

Fig. 2 - Frame format

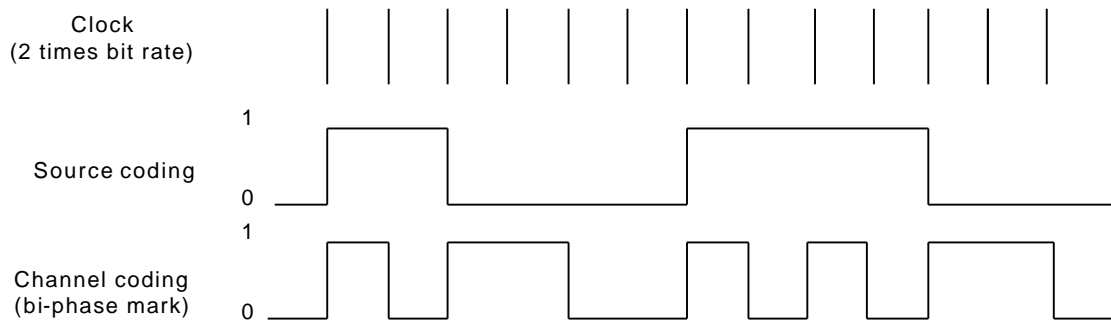

Fig. 3 - Channel coding

a) 2-channel mode

In 2-channel mode the samples from both channels are transmitted in consecutive sub-frames. Channel 1 is in sub-frame 1 and channel 2 is in sub-frame 2.

b) Stereophonic mode

In stereophonic mode the interface is used to transmit stereophonic audio in which the two channels are presumed to have been simultaneously sampled. The left or "A" channel is in sub-frame 1 and the right or "B" channel is in sub-frame 2.

c) Single channel mode (monophonic)

In monophonic mode the transmitted bit rate shall remain at the normal 2-channel rate and the audio sample word shall be placed in sub-frame 1. Time slots 4 to 31 of sub-frame 2 shall either carry the identical bits to sub-frame 1 or shall be set to logic "0". A receiver shall normally default to channel 1 unless manual override is provided.

(d) Primary/Secondary mode

In some applications requiring two channels where one of the channels is the main or primary channel while the other is a secondary channel, the primary channel is in sub-frame 1 and the secondary channel is in sub-frame 2,

2.3. Channel coding

To minimise the direct current (DC) component on the transmission line, to facilitate clock recovery from the data stream and to make the interface insensitive to the polarity of connections, time slots 4 to 31 are encoded in bi-phase-mark.

Each bit to be transmitted is represented by a symbol comprising two consecutive binary states. The first state of a symbol is always different from the second state of the previous symbol. The second state of the symbol is identical to the first if the bit to be transmitted is logic "0", however, it is different if the bit is logic "1" (see Fig. 3).

2.4. Preambles

Preambles are specific patterns providing synchronisation and identification of the sub-frames and blocks.

To achieve synchronisation within one sampling period and to make this process completely reliable, these patterns violate the biphase mark code rules. Thereby avoiding the possibility of data imitating the preambles.

A set of three preambles is used. These preambles are transmitted in the time allocated to four time slots at the start of each sub-frame (time slots 0 to 3) and are represented by eight successive states.

The first state of the preamble is always different from the second state of the previous symbol (representing the parity bit). Depending on this state the preambles are:

Preceding state:	0	1	
	channel coding		
"X"	11100010	00011101	Sub-frame 1
"Y"	11100100	00011011	Sub-frame 2
"Z"	11101000	00010111	Sub-frame 1 + block start

As with biphase code, these preambles are DC free and provide clock recovery. They differ in at least two states from any valid biphase sequence.

Fig. 4 represents preamble "X".

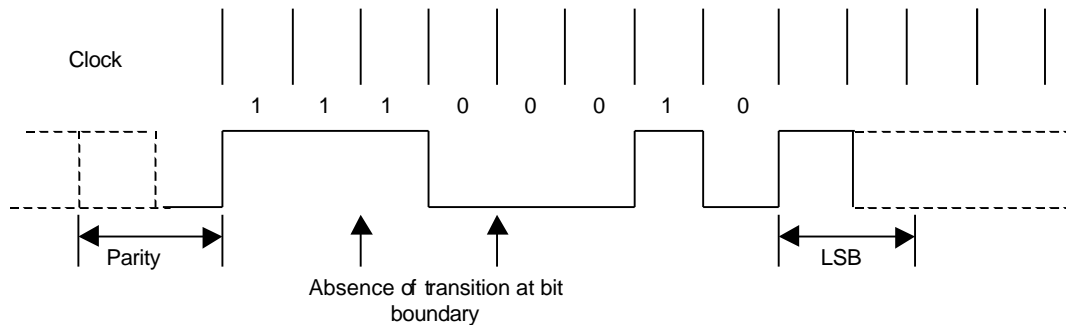

Fig. 4 Preamble "X" (11100010)

Note: Owing to the even parity bit in time slot 31, all preambles will start with a transition in the same direction (see *Section 3.2.1.*). Thus only one of these sets of preambles will, in practice, be transmitted through the interface. However, it is necessary for either set to be decodable because a polarity reversal may occur in the connection.

2.5. Validity bit

The validity bit shall be logic "0" if the audio sample word is suitable for conversion to an analogue audio signal and it shall be logic "1" if it is not.

There is no default state for the validity bit

3. User data format

User data bits may be used in any way desired by the user.

Channel status Byte 1 bits 4-7 indicate possible formats for the user data channel.

The default value of the user data bit shall be logic "0".

4. Channel status format

The channel status for each audio signal carries information associated with that audio signal, and thus it is possible for different channel status data to be carried in the two sub-frames of the digital audio signal. Examples of information to be carried in the channel status are: length of audio sample words, number of audio channels, sampling frequency, time code, alphanumeric source and destination codes, and pre-emphasis.

Channel status information is organised in 92-bit blocks, subdivided into 24 Bytes (Fig. 5). The first bit of each block is carried in the Frame with preamble "Z".

The specific organisation follows, wherein the suffix 0 designates the first Byte or bit. Where multiple bit states represent a counting number, tables are arranged with most significant bit (MSB) first, except where noted as LSB first.

		Bit						
Byte	0	1	2	3	4	5	6	7
0	Use of channel status channel	Linear PCM identification	Audio signal pre-emphasis			Locking of source sample frequency	Sampling frequency	
1	Channel mode				User bit management			
2	Use of auxiliary sample bits			Source word length & source encoding history		Indication of alignment level		
3	Channel number							N=0
3	Channel number				Multichannel mode number		N=1	
4	Digital audio reference	Reserved	Sampling frequency				SF scaling flag	
5	Reserved							
6	Alphanumeric channel origin data							
7								
8								
9								
10	Alphanumeric channel destination data							
11								
12								
13								
14	Local sample address code (32-bit binary)							
15								
16								
17								
18	Time-of-day sample address code (32-bit binary)							
19								
20								
21								
22	Reliability flags							
23	Cyclic redundancy check character							

Fig. 5 - Channel status data format

Byte 0				
Bit 0				
	0	Consumer use of channel status block (see <i>Note</i>)		
	1	Professional use of channel status block		
Bit 1				
	0	Audio sample word represents linear PCM samples		
	1	Audio sample words used for purposes other than linear PCM samples		
Bits 2 to 4 Encoded audio signal emphasis				
<i>bit</i>	2	3	4	
	0	0	0	Emphasis not indicated. Receiver defaults to no emphasis with manual over-ride enabled.
	1	0	0	No emphasis. Receiver manual over-ride disabled.
	1	1	0	50/15 μ s emphasis. Receiver manual over-ride disabled.
	1	1	1	CCITT J.17 emphasis (with 6.5 dB insertion loss at 500 Hz). Receiver manual over-ride disabled.
All other states of bits 2-4 are reserved and are not to be used until further defined.				
Bit 5				
	0	Default, and source sampling frequency locked.		
	1	Source sampling frequency unlocked.		
Bits 6 to 7 Encoded sampling frequency				
<i>bit</i>	6	7		
	0	0	Sampling freq. not indicated. Receiver defaults to interface frame rate and manual over-ride or auto set enabled.	
	0	1	48 kHz sampling frequency. Manual over-ride or auto set disabled.	
	1	0	44.1 kHz sampling frequency. Manual over-ride or auto set disabled.	
	1	1	32 kHz sampling frequency. Manual over-ride or auto set disabled.	

Note 1: The significance of Byte 0 bit 0 is such that a transmission from an interface conforming to IEC 60958-3 "consumer use" can be identified, and receiver conforming only to IEC 60958-3 "consumer use" will correctly identify a transmission from a "professional use" interface as defined in this standard. Connection of a "professional use" transmitter with a "consumer use receiver or vice versa might result in unpredictable operation. Thus the following Byte definitions only apply when bit 0 = logic 1 (professional use of the channel status block).

Note 2: The indication of sampling frequency, or the use of one of the sampling frequencies that can be indicated in this Byte, is not a requirement for operation of the interface. The 0 0 state of bits 6 and 7 may be used if the transmitter does not support the indication of sampling frequency, the sampling frequency is unknown, or the sample frequency is not one of those that can be indicated in this Byte. In the latter case for some sampling frequencies Byte 4 may be used to indicate the correct value.

Note 3: When Byte 1, bits 1 to 3 indicate single channel double sampling frequency mode then the sampling frequency of the audio signal is twice that indicated by bits 6 to 7 of Byte 0.

Byte 1				
Bits 0 to 3		Encoded channel mode		
<i>bit</i>	0	1	2	3
	0	0	0	0
	0	0	0	1
	0	0	1	0
	0	0	1	1
	0	1	0	0
	0	1	0	1
	0	1	1	0
	0	1	1	1
	1	0	0	0
	1	0	0	1
	1	1	1	1
All other states of bits 0 to 3 are reserved and are not to be used until further defined.				
Bits 4 to 7		Encoded user bits management		
<i>bit</i>	4	5	6	7
	0	0	0	0
	0	0	0	1
	0	0	1	0
	0	0	1	1
	0	1	0	0
	0	1	0	1
All other states of bits 4 to 7 are reserved and are not to be used until further defined.				

Note: This system is defined in Supplement 1 to EBU Tech. 3250: format of the user data channel of the digital audio interface.

Byte 2	
Bits 0 to 2	Encoded use of auxiliary sample bits
<i>bit</i>	0 1 2
	0 0 0 Maximum audio sample word length is 20 bits (default). Use of auxiliary sample bits not defined
	0 0 1 Maximum audio sample word length is 24 bits, Auxiliary sample bits used for main audio sample data
	0 1 0 Maximum audio sample word length is 20 bits, Aux. sample bits carry a single coordination signal (Note 1)
	0 1 1 Reserved for user-defined applications
	All other states of bits 0-2 are reserved and shall not be used until further defined
Bits 3 to 5	Encoded audio sample word length of transmitted signal (Notes 2, 3 and 4)
<i>bit</i>	3 4 5
	<i>Audio sample word length H maximum length is 24 bits, as indicated by bits 0-2 above</i>
	<i>Audio sample word length if maximum length is 20 bits, as indicated by bits 0-2 above</i>
	0 0 0 Word length not indicated (default) Word length not indicated (default)
	0 0 1 23 bits 19 bits
	0 1 0 22 bits 18 bits
	0 1 1 21 bits 17 bits
	1 0 0 20 bits 16 bits
	1 0 1 24 bits 20 bits
	All other states of bits 3 - 5 are reserved and shall not be used until further defined,
Bits 6 to 7	Indication of alignment level
<i>bit</i>	6 7
	0 0 Alignment level not indicated
	0 1 Alignment to SMPTE RP155, alignment level is 20 dB below maximum code
	1 0 Alignment to EBU R68, alignment level is 18.06 dB below maximum code
	1 1 Reserved

Note 1: The signal coding used for the co-ordination channel is described in *Appendix 1* to this document.

Note 2: The default state of bits 3-5 indicates that the transmitter does not specify the number of active bits within the 20 or 24 bits coding range. The receiver should default to the maximum number of bits specified by the coding range and enable manual override or auto set.

Note 3: The non-default states of bits 3-5 indicate the number of active bits within the 20 or 24 bits coding range that might be active. This is also an indirect expression of the number of LSBs that are certain to be inactive which is equal to 20 or 24 minus the number corresponding to the bit state, The receiver should disable manual override and auto set for these bit states.

Note 4: Irrespective of the audio sample word length as indicated by any of the states of bits 3-5, the MSB is in time slot 27 of the transmitted sub-frame as specified in *Section 2.2.1*.

Byte 3	
Bit 7	Multichannel mode
	0 Undefined multichannel mode (default)
	1 Defined multichannel modes

The definition of the remaining bit states depends on the state of bit 7.

Bits 0 to 6	Channel number, when Byte 3 bit 7 is 0
Value	The channel number is the numeric value of the Byte, with bit 0 as the least significant bit, plus one.

OR

Bits 0 to 6	Multichannel mode, when Byte 3 bit 7 is "1"
<i>bit</i>	4 5 6
	0 0 0 Multichannel mode 0. The channel number is the numeric value of bits 0 to 3 of this Byte with bit 0 = LSB, plus one
	1 0 0 Multichannel mode 1. The channel number is the numeric value of bits 0 to 3 of this Byte with bit 0 = LSB, plus one
	0 1 0 Multichannel mode 2. The channel number is the numeric value of bits 0 to 3 of this Byte with bit 0 = LSB, plus one
	1 1 0 Multichannel mode 3. The channel number is the numeric value of bits 0 to 3 of this Byte with bit 0 = LSB, plus one
	1 1 1 User-defined multichannel mode. The channel number is the numeric value of bits 0 to 3 of this Byte with bit 0 = LSB, plus one
	All other states of bits 4 to 6 are reserved and are not to be used until further defined

Note 1: The defined multichannel modes identify mappings between channel numbers and function. The standard mappings are under consideration. Some mappings may involve groupings of up to 32 channels by combining two modes.

Note 2: For compatibility with equipment that is only sensitive to the channel status data in one sub frame the channel carried by sub frame 2 may indicate the same channel number as channel 1. In that case it is implicit that the second channel has a number one higher than the channel of sub frame 1 except in single channel double sampling frequency mode.

Note 3: When bit 7 is 1 the 4-bit channel number can be mapped to the channel numbering in bits 20 to 23 of the consumer mode channel status defined in IEC 60958-3. In this case channel A of consumer mode maps to channel 2, channel B maps to channel 3 and so on.

Byte 4	
Bits 0 to 1	Digital audio reference signal (as per AES11-1991)
<i>bit</i>	<i>0 1</i>
	0 0 Not a reference signal (default).
	0 1 Grade 1 reference signal.
	1 0 Grade 2 reference signal.
	1 1 Reserved and shall not be used until further defined.
Bit 2	Reserved
Bits 3 to 6	Sampling frequency
<i>bit</i>	<i>3 4 5 6</i>
	0 0 0 0 Not indicated (default)
	1 0 0 0 24 kHz
	0 1 0 0 96 kHz
	1 1 0 0 192 kHz
	0 0 1 0 Reserved
	1 0 1 0 Reserved
	0 1 1 0 Reserved
	1 1 1 0 Reserved
	0 0 0 1 Reserved for vectoring
	1 0 0 1 22.05 kHz
	0 1 0 1 88.2 kHz
	1 1 0 1 176.4 kHz
	0 0 1 1 Reserved
	1 0 1 1 Reserved
	0 1 1 1 Reserved
	1 1 1 1 User defined
Bit 7	Sampling frequency scaling flag
	0 No scaling (default)
	1 Sampling frequency is 1/1,001 times that indicated by Byte 4 bits 3 to 6, or by Byte 0 bits 6 to 7

- Note 1: The sampling frequency indicated in Byte 4 is not dependent on the channel mode indicated in Byte 1.
- Note 2: The indication of sampling frequency, or the use of one of the sampling frequencies that can be indicated in this Byte, is not a requirement for operation of the interface. The 0000 state of bits 3 to 6 may be used if the transmitter does not support the indication of sampling frequency in this Byte, the sampling frequency is unknown, or the sample frequency is not one of those that can be indicated in this Byte. In the later case for some sampling frequencies Byte 0 may be used to indicate the correct value.
- Note 3: The reserved rates of bits 3 to 6 of Byte 4 are intended for later definition such that bit 6 is set to define rates related to 44,1 kHz, except for state 1000, and clear to defined rates related to 48 kHz. They should not be until further defined.

Byte 5	
Bits 0 to 7	Reserved, and shall be set to logic "0" until further defined

Bytes 6 to 9	
Bits 0 to 7	Alphanumeric channel origin data
Value (each Byte)	7-bit ISO 646 (ASCII) data with no parity bit. LSBs are transmitted first with logic "0" in bit 7. First character in message is Byte 6. Non-printed control characters (codes 01 hex to 1F hex and 7F hex) are not permitted. Default value shall be logic "0" (code 00 hex = ASCII "NULL")

Bytes 10 to 13	
Bits 0 to 7	Alphanumeric channel destination data
Value (each Byte)	7-bit ISO 646 (ASCII) data with no parity bit. LSBs are transmitted first with logic "0" in bit 7. First character in message is Byte 6. Non-printed control characters (codes 01 hex to 1F hex and 7F hex) are not permitted. Default value shall be logic "0" (code 00 hex = ASCII "NULL")

Bytes 14 to 17	
Bits 0 to 7	Local sample address code
Value (each Byte)	32-bit binary value representing the first sample of current block. LSBs are transmitted first. Default value shall be logic "0".

Note: This has the same function as a recording index counter.

Bytes 18 to 21	
Bits 0 to 7	Time of day sample address code
Value (each Byte)	32-bit binary value representing the first sample of current block. LSBs are transmitted first. Default value shall be logic "0".

Note: This is the time-of-day laid down during the source encoding of the signal and shall remain unchanged during subsequent operations. A value of all zeros for the binary sample address code shall, for the purposes of transcoding to real time, or to time codes in particular, be taken as midnight (i.e. 00 h, 00 mm, 00 s, 00 frame). Transcoding of the binary number to any conventional time code requires accurate sampling frequency information to provide the sample accurate time.

Byte 22	
Bits 0 to 7	Reliability flags
Flag used to identify whether the information carried by the channel status data is reliable. If reliable the appropriate bits are set to logic "0" (default); if unreliable the bits are set to logic '1'.	
bit 0 to 3	Reserved and are set to logic "0" until further defined.
bit 4	Bytes 0 to 5
bit 5	Bytes 6 to 13
bit 6	Bytes 14 to 17
bit 7	Bytes 18 to 21

Byte 23	
Bits 0 to 7	Channel status data cyclic redundancy check character (CRCC).
Value	Generating polynomial is; $G(X) = X^8 + X^4 + X^3 + X^2 + 1$ The CRCC conveys information to test valid reception of the entire channel status data block (Bytes 0 to 22 inclusive). For serial implementations, the initial condition of all logic "1"s should be used when generating the check bits, with the LSB transmitted first. Default value is logic "0" for minimum implementation of channel status only (see Section 5.2.1.).

Note: Appendix 1 includes a diagram of the shift register circuit used to generate the code and two examples of channel status data, and the corresponding CRC Byte.

5. Interface format implementation

5.1. General

To promote compatible operation between items of equipment built to this specification it is necessary to establish which information bits and operational bits need to be encoded and sent by a transmitter and decoded by an interface receiver.

Documentation shall be provided describing the channel status features supported by the interface transmitters and receivers.

5.2. Transmitter

Transmitters shall follow all the formatting and channel coding rules established in earlier sections of this specification. Along with the audio sample word, all transmitters shall correctly encode and transmit the validity hit, user bit, parity bit, and the three preambles. The channel status shall be encoded to one of the implementations given below.

The following three implementations are defined: "minimum", "standard", and "enhanced". These terms are used to communicate in a simple manner the level of implementation of the interface transmission involving the many features of channel status. Irrespective of the level of implementation the reserved states of bits defined in section 4 shall remain unchanged.

5.2.1. Minimum implementation of channel status

The *minimum* implementation represents the lowest level of implementation of the interface that meets the requirements of this specification document. In the minimum implementation, transmitters shall encode and transmit channel status Byte 0, bit 0 with a state of logic "1" signifying "professional use of channel status block". All other channel status bits of Bytes 0 to Byte 23 inclusive shall be transmitted with the default state of logic "0". In this circumstance, the receiver will adopt the default conditions specified in Bytes 0 to 2.

If additional Bytes of channel status (which do not fully comply with the standard implementation, see Section 5.2.2.) are implemented as required by an application the interface transmitter shall be classified as a minimum implementation of channel status.

It should be noted that this implementation imposes severe operational restrictions on the receiving devices that may be connected to it. For example, receivers implementing Byte 23 will show a CRC error when the default value of logic "0" is received as the CRCC. Also, reception of the default value for Byte 0 bits 6-7 might cause improper operation in receiving devices not supporting manual override or auto set capabilities.

5.2.2. Standard implementation of channel status

The standard implementation provides a fundamental level of implementation that should prove sufficient for general applications in professional audio or broadcasting. In addition to conforming to the requirements described above for the minimum implementation, a standard implementation interface transmitter shall correctly encode and transmit all channel status bits in Byte 0, Byte 1, Byte 2 and Byte 23 (CRCC) in the manner specified in this document.

5.2.3. Enhanced implementation of channel status

In addition to conforming to the requirements described above for the standard implementation, the *enhanced* implementation shall provide further capabilities.

5.3. Receivers

Implementation in receivers is highly dependent on the application. Proper documentation shall be provided on the level of implementation of the interface receiver for decoding the transmitted information (validity, user, channel status, parity), and on whatever subsequent action is taken by the equipment of which it is a part.

6. Electrical requirements

6.1. General characteristic

The electrical parameters of the interface are based on those defined in ITU-T Recommendation V.11 for balanced voltage digital circuits, which allow signal transmission over distances of up to a few hundred metres.

A circuit conforming to the general configuration shown in figure 6 may be used.

Although equalization may be used at the receiver, there shall be no equalization before transmission.

The frequency range used to qualify the interface electrical parameters is dependent on the maximum data rate supported. The upper frequency is 128 times the maximum frame rate,

The interconnecting cable shall be balanced and screened (shielded) with nominal characteristic impedance of 110 Ω at frequencies from 0.1 to 128 times the maximum frame rate.

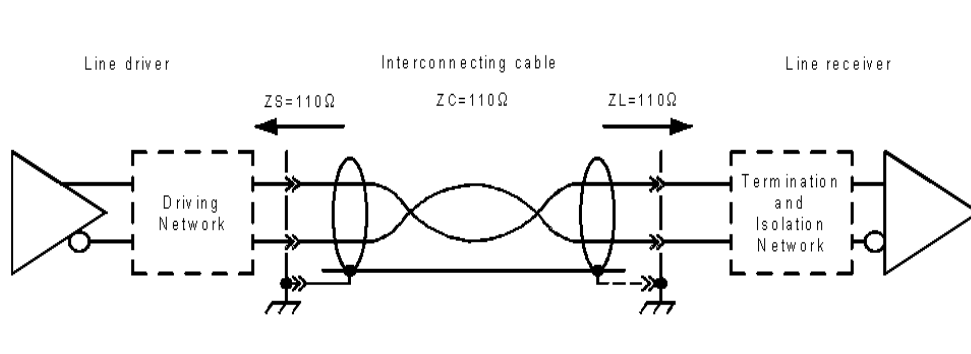

Fig. 6 – Simplified example of the configuration of the circuit (balanced)

- Note 1: Holding closer tolerances for the characteristic impedance of the cable, and for the driving and terminating impedances, can increase the cable lengths for reliable transmission and for higher data rates.
- Note 2: Closer tolerances for the balance of the driving impedance, the terminating impedance, and for the cable itself can reduce both electromagnetic susceptibility and emissions.
- Note 3: Using cable having lower loss and higher frequencies can improve the reliability of transmission for greater distances and higher data rates.

6.2. Line driver characteristics

6.2.1. Output impedance

The line driver shall have a balanced output with an internal impedance of $110 \Omega \pm 20\%$, at frequencies from 0.1 to 128 times the maximum frame rate when measured the output at terminals.

6.2.2. Signal amplitude

The signal amplitude shall lie between 2 and 7 V peak-to-peak, when measured across a 110Ω resistor connected to the output terminals, without any interconnecting cable present.

6.2.3. Balance

Any common mode component at the output of the equipment shall be more than 30 dB below the signal at frequencies from DC to 128 times the maximum frame rate.

6.2.4. Rise and fall times

The rise and fall times determined between the 10% and 90% amplitude points, shall be between 5 ns and 30 ns when measured across a 110Ω resistor connected to the output terminals, without any interconnecting cable present.

Note: Operation toward the lower limit of 5 ns will improve the received eye pattern but will increase EMI at the transmitter. Equipment must meet local regulations regarding EMI.

6.2.5. Output interface jitter

Jitter at the output of a device shall be measured as the sum of the jitter intrinsic to the device and jitter being passed through from the timing reference of the device.

6.2.5.1 Intrinsic jitter

The peak value of the intrinsic jitter at the output of the interface, measured at all the transition zero crossings shall be less than 0,025 UI when measured with the intrinsic-jitter measurement filter.

Note1: This requirement applies both when the equipment is locked to an effectively jitter-free timing reference, which may be a modulated digital audio signal, and when the equipment is free-running.

Note 2: The intrinsic-jitter measurement filter characteristic is shown in figure 7. It shows a minimum-phase high-pass filter with 3 dB attenuation at 700 Hz, a first order roll-off to 70 Hz and with a pass-band gain of unity.

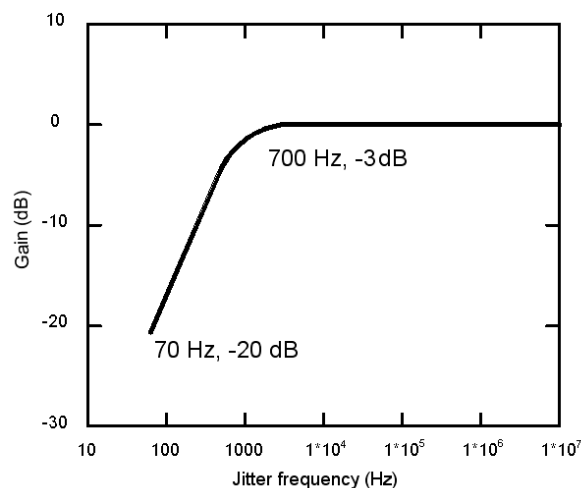

Fig.7 – Intrinsic-jitter measurement-filter characteristic

6.2.5.2 Jitter gain

The sinusoidal jitter gain from any timing reference input to the signal output shall be less than 2 dB at all frequencies.

Note: If jitter attenuation is provided and it is such that the sinusoidal jitter gain falls below the jitter transfer function mask of figure 8 then the equipment specification should state that the equipment jitter attenuation is within

this specification. The mask imposes no additional limit on low-frequency jitter gain. The limit starts at the input-jitter of 500 Hz where it is 0 dB, and falls to -6 dB at and above 1 kHz.

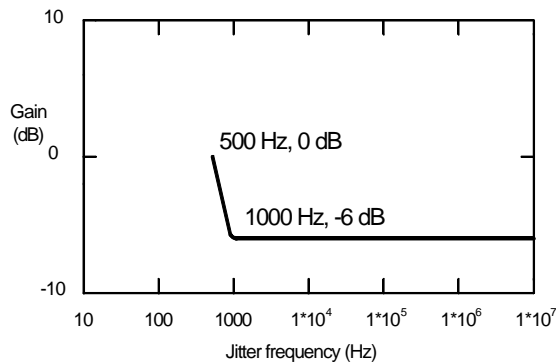

Fig.8 – Jitter transfer-function mask

6.3. Line receiver characteristics

6.3.1. Terminating impedance

The receiver shall present a substantially resistive impedance of 110 Ω ± 20% to the interconnecting cable over the frequency hand 0.1 to 6.0 MHz, when measured across the input terminals. The application of more than one receiver to any one line might create transmission errors due to the resulting impedance mismatch.

6.3.2. Maximum input signals

The receiver shall correctly interpret the data when connected directly to a line driver working between the extreme voltage limits specified by Section 6.2.2.

Note: In EBU document Tech. 3250 (1985) the specification for line driver signal amplitude was 10 V peak-to-peak maximum.

6.3.3. Minimum input signals

The receiver shall correctly sense the data when a random input signal produces the eye diagram characterised by a V_{min} of 200 mV and T_{min} of 50% of T_{nom} (see Fig. 9).

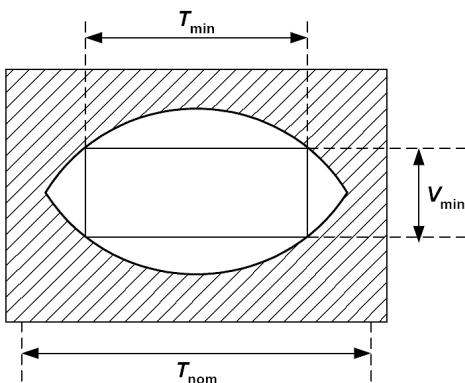

T_{min} = 0.5 x T_{nom}
 V_{min} = 200mV
 T_{nom} = one half of biphase symbol period

Fig. 9 - Eye diagram

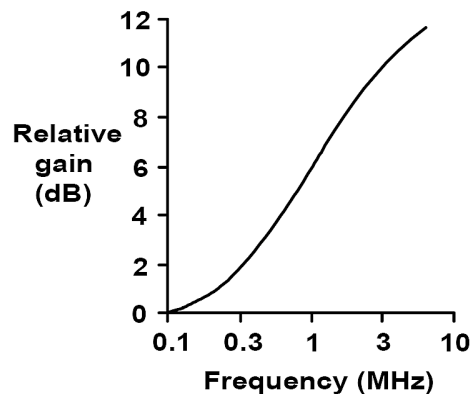

Fig. 10 - Suggested equalizing characteristic for a receiver operating at 48 kHz frame rate

6.3.4. Receiver equalization

Optional equalization can be applied in the receiver to enable interconnecting cable longer than 100 m to be used. A suggested frequency-equalizing characteristic for operation at frame rates of 48 kHz is shown in Fig. 10. The receiver shall meet the requirements specified in Sections 6.3.2. and 6.3.3.

6.3.5. Common mode rejection

There shall be no data errors introduced by the presence of a common mode signal of up to 7 V peak at frequencies from DC to 20 kHz.

6.3.6. Receiver jitter tolerance

An interface data receiver should correctly decode an incoming data stream with any sinusoidal jitter defined by the jitter tolerance template of figure 11.

Note: The template requires a jitter tolerance of 0.25 UI peak-to-peak at high frequencies, increasing with the inverse of frequency below 8 kHz to level off at 10 UI peak-to-peak below 200 Hz.

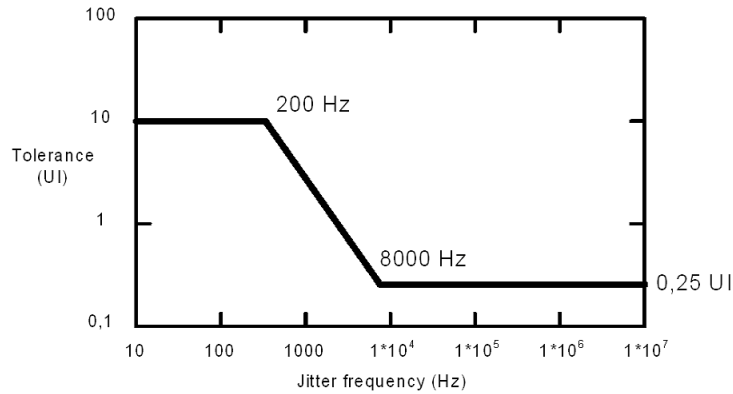

Fig.11 – Jitter tolerance template

6.4. Connectors

The standard connector for both outputs and inputs shall be the circular latching three-pin connector described in IEC 60268-12 (this type of connector is normally called "XLR").

An output connector fixed on an item of equipment shall use male pins with a female shell. The corresponding cable connector shall thus have female pins with a male shell.

An input connector fixed on an item of equipment shall use female pins with a male shell and the corresponding cable connector shall thus have male pins with a female shell. The pin usage shall be:

Pin 1:	Cable shield or signal earth,
Pin 2:	Signal
Pin 3:	Signal

(Note that the relative polarity of pins 2 and 3 is not important in the digital case).

Equipment manufacturers should clearly label digital audio inputs and outputs as such, including the terms "digital audio input" or "digital audio output" as appropriate.

In such cases where panel space is limited and the function of the connector might be confused with an analogue signal connector, the abbreviations "DI" and "DO" should be used to designate digital audio inputs and outputs, respectively.

Appendix 1 Generation of the CRCC (Byte 23) for channel status

The channel status clock format of 192 bits includes a cyclic redundancy check (CRC) code that occupies the last 8 bits of the block (Byte 23). The specification for the code is given by the generating polynomial:

$$G(X) = x^8 + x^4 + x^3 + x^2 + 1$$

An example of a hardware realisation in the serial form is given in Fig. A.1. The initial condition of all the stages is logic "1".

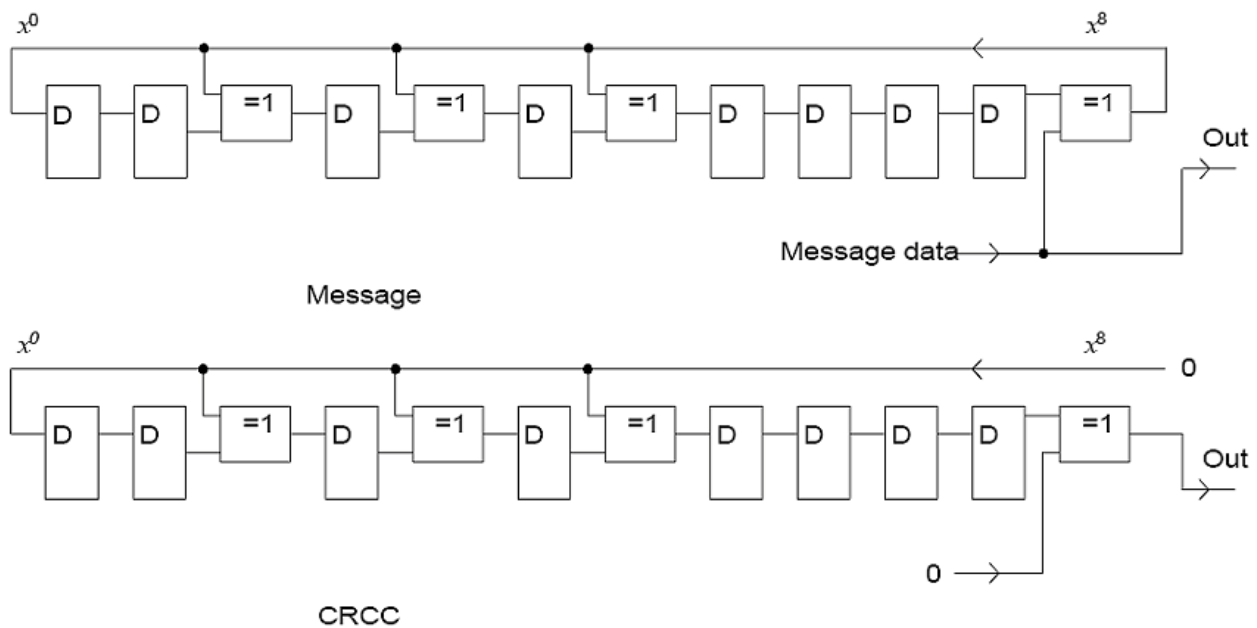

Fig. A.1. - Flow diagram of an example realisation of the CRCC generator.

Two examples of the channel status data and the resultant CRCC follow:

Example 1

Content of channel status data (Bytes 0 to 22 inclusive):

Byte	Bits set to logic "1"
0	0,2,3,4,5
1	1
4	1

All other bits in channel status Bytes 0 to 22 inclusive set at logic "0".

Content of CRCC (Byte 23):

Bits	0	1	2	3	4	5	6	7
Channel status bits:	184	185	186	187	188	189	190	191
Value	1	1	0	1	1	0	0	1

Example 2

Content of channel status data (Bytes 0 to 22 inclusive):

Byte	Bits set to logic "1"
0	0

All other bits in channel status Bytes 0 to 22 inclusive set at logic "0".

Content of CRCC (Byte 23):

Bits	0	1	2	3	4	5	6	7
<i>Channel status bits:</i>	184	185	186	187	188	189	190	191
Value	0	1	0	0	1	1	0	0

Note: No particular level of implementation should be taken as implied by the examples given in this *Appendix*.

Appendix 2

AES/EBU signals on Structured Wiring

There is an increasing use of structured wiring for carrying AES3 signals. Notwithstanding clause 6.1, the practice has been shown to be viable on Category 5 unshielded pairs, meeting EMI requirements, and offering transmission up to 400 metres overall unshielded, or 800 metres shielded, at 48 kHz frame rate.

For a satisfactory outcome, this practice should only be used where the whole length of the connection uses Category 5 UTP (Unshielded Twisted Pair) cable, including that which is installed and any flexible leads (equipment cords), and that the connection is unshielded for the whole length. Alternatively, the whole length of the connection should use Category 5 STP (Shielded Twisted Pair), and the connection should be shielded for the whole length.

Care should be taken in design of the interface to provide adequate balance on the twisted pair within the Cat.5 cable.

Using RJ45 connectors, conventionally wired, current practice favours the use of pins 4 and 5 for AES/EBU signals (separating them from ATM signals on the same cable). Pins 3 and 6 are the preferred second pair. Note that, for full protection, the interface may have to withstand power voltages specified to support network equipment, and the use of transformers and blocking capacitors on the AES/EBU interface is strongly recommended.

Suggested practice: while the interface is by definition insensitive to polarity, for the purposes of constructing adaptors, XLR Pin 2 should be connected to RJ45 Pin 5 (or other odd-numbered pin), XLR Pin 3 should be connected to RJ45 Pin 4 (or even-numbered pin).

Bibliography

- IEC Publication 268-11 (1987):** Sound system equipment, Part 11: Application of connectors for the interconnection of sound system components.
- IEC Publication 268-12 (1987):** Sound system equipment Part .12: Application of connectors for broadcast and similar use.
- ITU-R Recommendation BS647:** A digital audio interface for broadcasting studios
- IEC Publication 60958-1:** Digital audio interface – Part 1: General
- IEC Publication 60958-4:** Digital audio interface- Part 4: Professional applications.
- EBU Technical Recommendation R68-2000:** Alignment level in digital audio production equipment and in digital audio recorders
- AES11-1991:** AES Recommended practice for digital audio engineering - Synchronization of digital audio equipment in studio operations.
- EBU document Tech. 3250 - Supplement 1, 1992:** Format, for the user data channel of the digital audio interface (The AES/EBU interface)